

ASSEMBLY GUIDE - Single Width

This assembly guide is designed to provide you with step by step instructions to ensure your system is erected easily and safely using the 3T (Through the Trap) Safety Standard. Before assembly please read the safety notes carefully. Eiger 500 is a mobile access tower system complying with EN 1004:2004 and WAHR, with vertical ladder access, designed for Class 3 loading. Platform heights 1.2m to 8.2m internal / external and platform heights 8.7m to 12.2m internal only.

EN1004 - 3 - 8/12 - D

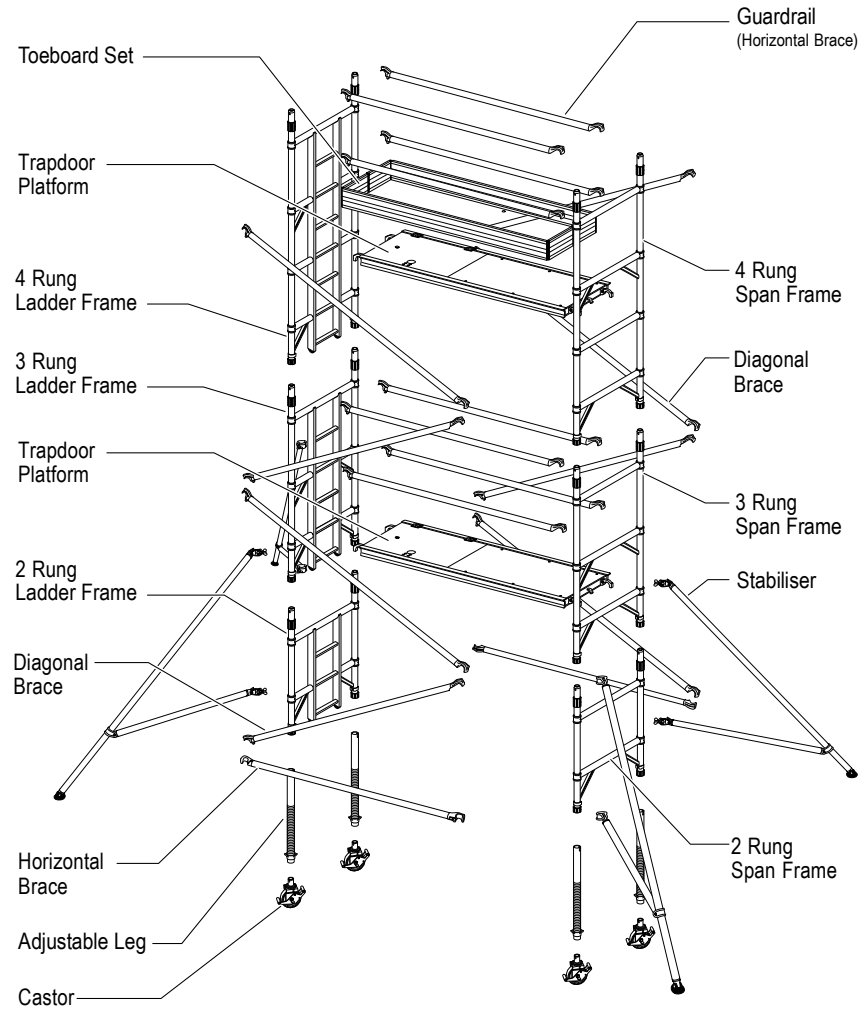

COMPONENT SCHEDULE	Internal or External Use		Internal Use Only	
	Unit (kg)	Weight (kg)	Unit (kg)	Weight (kg)
Working Height	WH 3.2	3.7	4.2	4.7
Castor	PH 1.2	1.7	2.2	2.7
Adjustable Leg		4	4	4
2 Rung Ladder Frame		4	4	4
2 Rung Span Frame		0	1	0
3 Rung Ladder Frame		0	1	0
3 Rung Span Frame		0	1	0
4 Rung Ladder Frame		0	1	0
4 Rung Span Frame		0	1	0
Trapdoor Platform	1.8m / 2.5m	1	1	1
Horizontal Brace	1.8m / 2.5m	6	6	6
Diagonal Brace	2.1m / 2.7m	2	3	4
Toeboard Set	1.8m / 2.5m	1	1	1
Fixed Stabiliser		0	0	0
Telescopic Stabiliser		0	0	0
Sent Jumbo Stabiliser		0	0	0
Balustrade (kg)		0	0	0
Total Tower Weight 1.8M (kg)		73.42	84.37	106.53
Total Tower Weight 2.5M (kg)		82.24	93.79	116.55
		160	167.13	174.25
		156.11	162.64	173.94
		208.37	220.1	238.72
		233.15	257.15	292.33
		256.48	273.1	314.06
		297.53	309.71	350.03
		344.06	357.16	371.41
		320.58	364.28	371.41
		327.11	357.16	371.41

SAFETY CHECK LIST	
All Components free from damage	
Castors Locked	
Tower Level	
Screwclamps Secure	
All Platforms Fully Guardrailed	
Claws Locked Correctly	
Windlock Catches Engaged	
Interlock Clips Engaged	
Toeboards Correctly Positioned on ALL Work Platforms	

DAMAGED COMPONENTS

Damaged components found during inspection must be quarantined until assessed and repaired by a qualified repairer or replaced with repairer or replaced with new components.

DO NOT use damaged components in the tower structure.

DESCRIPTION

The Eiger 500 Access Tower gives a work platform for use by up to two persons, with weight evenly distributed across the two decks. The information and instructions included in this manual are provided to help you get the best possible service from your Eiger 500 Access Tower. To ensure that the tower is used safely and responsibly, we strongly recommend that these instructions are read by everyone involved in its erection and use prior to assembling and using the tower, and that the recommendations are followed at all times.

SAFETY

Before using this access tower and to avoid personal injury, carefully read and understand these instructions. If there is anything you do not understand, DO NOT use this access tower, contact the supplier for advice.

Make sure you are aware of all safety requirements and that this access tower is suitable for the task you wish to undertake. The work area must be cordoned off to create a safe zone from the general public and bystanders. The safe zone must be a minimum of 3m radius or 1m greater than the platform height being used.

This access tower must not be set up, used, moved or dismantled by persons who are under the influence of alcohol or drugs. Do not use this access tower if you are tired or unwell. This access tower must only be used by persons who are medically fit to do so. If you have any medical condition, are recovering from any medical condition or suffer from any mental or physical disability, you MUST seek professional medical advice before using this access tower.

The persons assembling this tower must be competent and qualified to do so.

Weights

The tower itself, regardless of size, has a maximum total SWL (Safe Working Load) of 1000kg. This is the maximum load that can be placed on the castors. When checking SWL for your tower, you must firstly deduct the tower's self weight from its overall SWL to give you the maximum payload (users plus tools and materials). You must also ensure that a platform's SWL is not exceeded.

Do not overload the platform/s beyond the stated weight loading. Single platform up to 294Kg evenly distributed. The maximum number of working platforms per tower must not exceed two.

Wear the correct Personal Protective equipment for the task you are performing.

Wear gloves when handling tower components.

Wear suitable clothing. Steel toecap boots must be worn. If appropriate, wear a hard hat.

Do not wear loose jewellery or clothing that may get in the way or become trapped in the access tower. Tie back long hair.

The tower must not be used in adverse weather conditions IE: heavy rain, snow or ice. If the tower becomes contaminated by paints, chemicals or similar materials, the tower must not be used until such contaminants have been completely removed.

You MUST perform a risk assessment before using this access tower to ensure your safety and the safety of others. Do not use this access tower where there are overhead power lines or similar hazards within your reach and that of the tower.

If leaving an erected tower unattended you must block access to the tower by unauthorised persons. Use suitable mesh fencing or boarding to make access impossible. If you cannot block access, the tower MUST be dismantled.

Do not suspend the tower from another structure.

Assembly Guide designation - EN1298 - IM - EN

Only carry tools and materials with you when ascending/ or descending the tower if they are safely retained in a tool belt and not restricting free movement. Tools/materials may be hoisted to the deck via a rope. PROPERLY ASSESS THE RISK/METHOD.

Do not lean from the tower and never apply undue side force. Maximum permitted side load must not exceed 20Kg (200N). Never use boxes, steps or similar items to gain additional height. Do not use the tower to gain access to another structure. NEVER stand on the hand/guard rails, toe boards, horizontal or diagonal bars. Always use the towers built in ladders to access platforms and climb from inside the tower NEVER from the outside. When climbing, always keep your feet in the middle of the rungs and grip the upper rungs with your hands NEVER the sides.

When wind exceeds Beaufort force 4, cease to use the tower. Wind Speeds:

4	18	29	Moderate breeze - raises dust and loose paper
6	31	50	Strong breeze - difficult to use umbrella
8	46	74	Gale force - walking is difficult

PREPARATION

Clear the floor area of all obstacles and debris. Where possible sweep the floor. Check the ground upon which the tower is to be used is capable of supporting the combined weight of the tower and any necessary loading. The ground should be level and any slope should be within the scope of the adjustable legs. Ensure all tools and equipment required to erect the tower are available and on site.

Check each component for condition and correct operation BEFORE you start assembling the tower. Any faulty or damaged items MUST be replaced before assembling the tower. As you inspect each part, segregate types to make the task easier.

COMPONENTS

Fitted to horizontal and diagonal braces, each has a trigger that opens the jaw to allow attachment to a frame tube.

All claws (except the first base assembly horizontal braces) must only be attached to the top of a horizontal frame tube. Attachment to a vertical frame tube will not fully protect the user and may cause serious injury or death.

The trigger will be colour coded to identify horizontal or diagonal braces. Red for horizontal and blue for diagonal. Always double check that each claw is positively locked in position before using the tower.

Pin Clip Stabilizer Leg

Upper Frame Screw Clamp

Interlock Clip

Lower Frame

Interlock Clip...

The interlock clip is a spring clip fitted with a pin that locates into a retaining hole. These are used to lock tower sections together when placed one on top of the other.

formworkdirect.co.uk
TEL:
(+44) (0)151 532 0179
EMAIL
sales@formworkdirect.co.uk



formworkdirectmalta.com
TEL:
+356 2124 4241
EMAIL
sales@formworkdirectmalta.com

Pin Clip...

Are used to lock a stabiliser's extendable leg at the selected length.

Screw Clamps...

The screw clamps are used to secure the stabilisers to the tower's vertical corner tubing.

Wind-lock Catch...

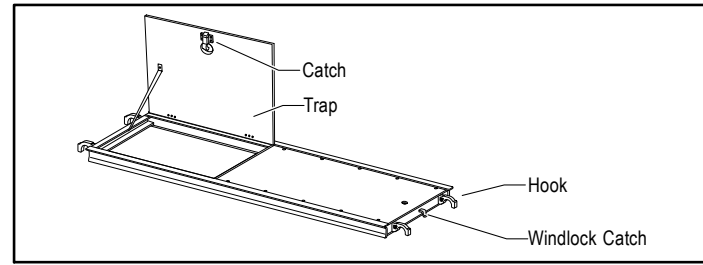

Fitted to both ends of all platforms, the wind-lock catch is a bar that slides out and under the tower frame's horizontal bar or ladder rung. The catch is used to stop the platform being lifted by gusts of wind.

TYING IN

Please refer to PASMA guide 'Tying Mobile Towers' available for download at <http://pasma.org.uk/shop>.

3T (THROUGH THE TRAPDOOR) SYSTEM

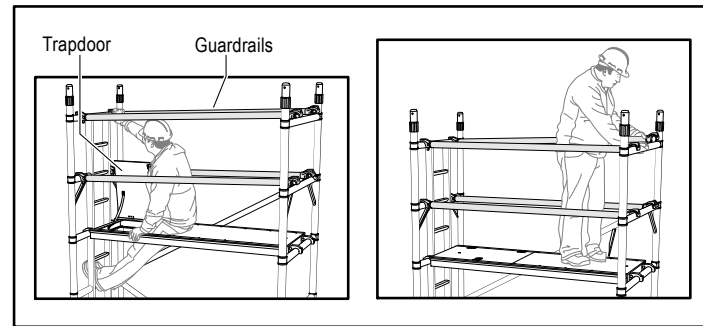

This method of construction reduces the risk from a fall. You will complete an 'assembly' platform from which to add the next lift, then another platform until the final height is reached.

Using standard components, the erector will always be protected by a set of guardrails (Horizontal Braces). These will be attached to the frames whilst the erector sits on the platform with legs through the trapdoor.

USE THIS METHOD! It has been developed for your safety. If you ignore it, you risk serious injury or death.

DISMANTLING THE TOWER

Dismantle the tower by reversing the erection sequence but pay special attention to the following procedure regarding the 3T system.

You MUST always be protected by a full set of guardrails when standing on a platform. When dismantling using the 3T system, the claws on the end of the braces that are positioned furthest from the trapdoor, will need to be disconnected before you sit within the trapdoor.

This should be performed with the greatest of care, and once disconnected you should go directly to the trapdoor and sit on the platform with your feet on the lower ladder rungs.

From this position you can disconnect the remaining claws and remove the braces.

EQUIPMENT MAINTENANCE & CLEANING

Keep all components clean and free from contaminants. If any part becomes contaminated with paint, acid, oils or similar products, the tower must not be used until the effected components have been cleaned.

TRANSPORTATION AND STORING

All components should be stored in a dry location where they will be protected from adverse weather conditions. When storing or transporting, keep frames upright and platform decks flat. Do not 'stack' excessively to avoid stress damage.

INSTRUCTION LEAFLET AVAILABILITY

Keep these instructions in a safe place and ensure that they are made available to anyone using, constructing or dismantling the tower. If these instructions become lost or illegible, replacements should be acquired from the manufacturer.

MOVING A TOWER

If you need to move the tower to a new location or a new level, fully dismantle it and rebuild at the new location.

If moving the tower a small distance, remove all personnel, materials, tools and anything else from the tower.

If the stabilisers can remain in position, reduce the tower to a platform height of 4 metres before moving. Raise the stabiliser's legs so that the footpads are approximately 25 mm off the ground.

If the stabilisers need to be removed or repositioned (i.e. swung in to allow access to a doorway) you must reduce the tower to a platform height of 2 metres.

With help, unlock all castors, move the tower then relock castors and level the tower ready for rebuilding to the required height.

The tower should only be moved by manual effort and only by pushing at the base.

BALLAST

Where shown in the component list, ballast must be used to stabilise against overturning. Only use solid materials as ballast (ie: no loose materials) and position to avoid overloading individual components. Ballast should be supported by the base of the tower and securely fastened to prevent removal.

STABILISERS

Stabilisers shall always be fitted where specified, these increase the stability as a free standing structure. Best effect is obtained from the stabilisers when they are arranged in a footprint as near to a square. (see fig 1). When using the tower against a wall, they may be positioned as in fig 2, but the wall must be at least two thirds the height of the top working platform. When locating stabilisers on towers, maximum stability will be achieved by positioning at an angle of 45 degrees. Extend stabiliser leg to maximum adjustment and ensure that the top coupler is positioned underneath the frame tee-casting. Securely lock the top coupler before attaching the lower arm to the frame upright. Ensure that the rubber foot is in contact with the ground and that the ground can support the weight of the tower and stabilisers.

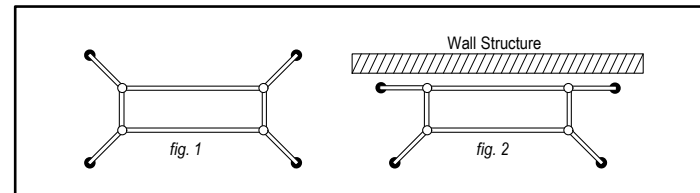

GETTING STARTED

The Eiger 500 access tower is available in 2 base sizes, 850mm by a 1.8m or 2.5m platform length. The tower will be supplied with various height frames and you must always start with the smallest size frames first. The following instructions deal with a tower using two rung frames at the start, if supplied with three rung instead of two rung, start with the three rung frames.

Where you have both two rung and three rung, you must use the two rung first and the three rung next, with (where applicable) four rung frames at the top. The first two platforms need to be carefully positioned to ensure that the remaining tower is constructed safely, use the chart below to find the exact position for the tower height you are erecting.

The access tower requires a minimum of two persons to assemble it, do not attempt to assemble the tower on your own.

Tower Platform Height (Mtrs)	Reposition Platform & Guardrails from 1st Rung 0.70m to working level	Reposition Platform & Guardrails from 2nd Rung 1.20m to working level	Reposition Platform & Guardrails from 3rd Rung 1.70m to working level	Reposition Platform & Guardrails from 3rd Rung 1.70m to working level
2.70				
4.70				
5.20				
5.70				
6.20				
6.70				
7.20				
7.70				
8.20				
8.70				
9.20				
9.70				
10.20				
10.70				
11.20				
11.70				
12.20				

BUILD PROCESS

For Single Width 1450 Tower 4.20Mtr Platform Height

Step 1.
Insert castor / adjustable leg assemblies into base of 2 rung ladderframe and one standard end frame, allowing approximately 75mm of extended leg for levelling. Press down firmly on the braking mechanism to lock castors.

Step 2.
Fit a horizontal (Red) brace onto the vertical member of one frame, resting directly onto the alloy casting at the first horizontal rung position. Ensure that the sprung trigger faces to the outside of the tower.

Step 3.
Join the second base frame to the first ensuring brace hook again rests directly onto the alloy casting. Fit second horizontal brace in corresponding position. Level around base of tower using a spirit level, making adjustments as necessary to adjustable legs.

Step 4.
Locate 4 rung frames and fit diagonals onto lowest rungs, attach stabilisers to each corner.

Step 5.
Locate trap door platform on fourth rung 2.20m level above ladder ensuring the trapdoor faces outwards.

Step 6.
Using the 3T method position yourself in the hatch and fit 4 guardrail braces on the fifth and sixth rungs either side of the platform. Access the platform and secure guardrails and diagonal brace at opposite end of the tower.

Step 7.
Fit next lift of 4 rung frames and attach diagonal braces.

Step 8.
If working height of the tower is achieved on this frame, locate a trapdoor platform on the eighth rung. This is the 4.20m level.

Step 9.
Using the 3T method install 4 guardrail braces onto 9th and 10th rungs to both sides of the tower.

Step 10.
Access the platform and secure the guardrails and diagonal brace at the opposite end of tower.
NOTE: If building the tower beyond the 4.20mtr level, continue with steps 4 & 5 until desired working height is achieved, then follow step 8.

Step 11.
Fit the toeboard assembly.